



ALB10

INSTALLATION/OWNER'S MANUAL

10" Ported Enclosure with Built-in Amplifier



PREPARATION

Getting Started

Thank you for purchasing the Dual ALB10 10" ported enclosure with built-in amplifier. Although Dual has attempted to ensure the information in this manual is accurate, please be aware that any part of it is subject to change without notice.

Please read entire manual before installation. Due to the technical nature of amplifiers, it is highly recommended that your Dual ALB10 is installed by a professional installer or an authorized dealer.

Before You Start

- Always disconnect the negative battery terminal. Consult a qualified technician for instructions if you are unsure.
- Avoid installing the amplifier where it would be subject to high temperatures, such as from direct sunlight, or where it would be subject to dust, dirt or excessive vibration.
- Use extreme caution when drilling holes to avoid damaging fuel lines or existing vehicle wiring.
- All amplifier installations require power, signal and speaker wires (not included).
- An amplifier installation kit (sold separately) is highly recommended to facilitate the installation. Consult your dealer for recommendations.

Mounting Location

- Choose a mounting location for the ALB10. Suggested locations include behind a seat or in the trunk.
- For optimum performance, make sure to provide at least 1" of space around all sides of the amplifier.
- Do not mount the ALB10 under carpets or where airflow is restricted.
- Do not install the ALB10 where it may be exposed to moisture.
- The optimum mounting location varies between vehicles. Remember to test all amplifier functions before completing the final mounting procedure.

INSTALLATION

Safety First



CAUTION

The following instructions are designed to ensure safety during installation and use of the ALB10. Failure to heed these instructions can result in injury or damage to the unit or vehicle.

The following installation instructions are intended to be used as a basic guideline. If you feel unsure about installing this speaker system yourself, Dual recommends acquiring the services of a professional car audio installation center.

Before installation, please review the following guidelines:

1. Be sure to carefully read and understand the instructions before attempting to install this product.
2. If additional wiring is required, we recommend running all wires prior to mounting your enclosure in place.
3. To ensure reliable performance and minimize signal or power loss, use the highest quality connectors available.
4. Never run speaker wires underneath your vehicle. Running speaker wires inside the vehicle provides the best protection from exhaust, heat and environmental elements.
5. Avoid running wires over, near or through sharp-edged surfaces. We suggest you also use rubber grommets to protect any wires routed through metal, especially the firewall.
6. When running the speaker cable to the amplifier, avoid running it near sources of high current (i.e. wiring harnesses, battery cables).

INSTALLATION

Connection Descriptions

Note: Be sure to follow specific instructions included with your amplifier installation kit (not included with this amplifier). The information below should be used a general guideline only.

Power Wire (+12V)

- Disconnect negative battery terminal before proceeding. Consult a qualified technician for instructions if you are unsure.
- Plan wire routing before cutting any wires to length. Begin by routing the power +12V wire from the battery to the amplifier location. Use a grommet when running wires through the firewall or metal openings. Avoid running the power wire near existing vehicle wiring to prevent induced noise from entering the audio system.
- Use extreme caution when drilling holes to avoid damaging fuel lines or existing vehicle wiring.
- The +12V wire **MUST** be fused within 18" of the battery for protection of the vehicle's electrical system.

Ground Wire (GND)

- The amplifier ground wire should be as short as possible. Choose a clean unpainted section of metal or the vehicle chassis when attaching the ground connection. Be sure to clean the area of any dirt or grease.

Remote Turn-on Wire (REM)

- The remote turn-on wire connects to the head unit's amplifier turn-on lead or other switched 12 volt source.

Input Signal

- The amplifier's input signal connects to the head unit's low level (RCA) outputs.

CAUTION

- Never run any wires underneath or outside the vehicle.

INSTALLATION

Connections and Controls



- ① Hi-Level Inputs
- ② Line In (Left)
- ③ Line In (Right)
- ④ Crossover Frequency
- ⑤ Input Level Control
- ⑥ Phase Control

- ⑦ Power Indicator
- ⑧ Ground Connection
- ⑨ Remote Connection
- ⑩ Power Connection
- ⑪ Fuse (15A)

INSTALLATION

Typical Wire Routing

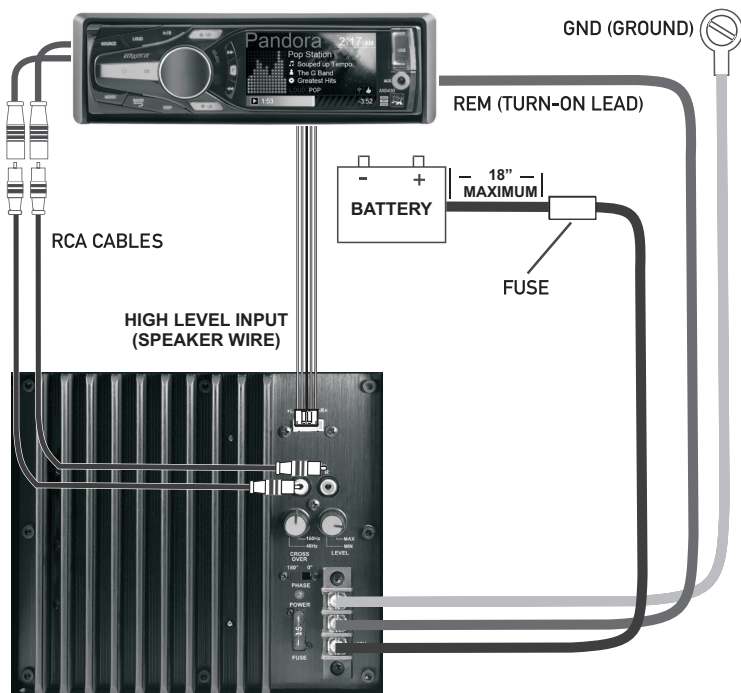

High Level Input (Speaker Wire)

High level inputs should only be used when RCA outputs are not available from the head unit. Connect the head unit speaker outputs to the high level input connector as shown below. The black wire (signal reference ground) may or may not require a connection to chassis ground - depending on your particular installation. **Do not use both low and high level inputs at the same time. Connect only one or the other.**

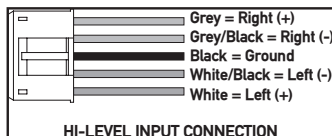

Main Power Connections

Connect BAT+, GND and REM wires accordingly. A suitable fuse **MUST** be installed on the BAT+ lead within 18" of the battery for protection of the vehicle's electrical system.

Fuse Rating

When replacing the fuse, make sure new fuse is the correct type and amperage. Using an incorrect fuse could damage the amplifier. The ALB10 uses (1) **15 amp** ATO style fuse.

Power/Ground Wire Size

For optimum performance, use only **12 gauge** wire or larger. Make sure to use the same size power and ground wire.

INSTALLATION

Control Setup and Adjustment

Input Signal Connections Low Level (RCA)	Low level (RCA) input signal is preferred for best performance. Typical trunk-mount installations require a 17-20 foot RCA cable. Most trucks and behind-seat applications require a 6-12 foot RCA cable. Using twisted pair construction RCA cables will minimize noise.
Crossover Frequency Control	The adjustable crossover is used to filter out frequencies above 40Hz ~ 160Hz. Adjust it to where the ALB10 sound output blends with the rest of the sound system.
Phase Control	The phase control compensates for delay between the ALB10 output and the rest of the sound system. Begin with the phase control set to 0 degrees. If the sound is adequate from the normal listening position inside the vehicle, no further adjustment is necessary. If the sound is thin or lacking bass, adjust the phase control until the bass is full and punchy.
Input Level Control	The input level control (LEVEL) is used to obtain the best possible match between the head unit audio output and the amplifier input. Begin by turning the input level control fully counterclockwise. Next, turn up the head unit volume control around 3/4 of the way up. Adjust the input level control clockwise until audible distortion is heard, then slightly counterclockwise to provide the best match.
LED Indicator	The LED indicator illuminates green during normal operation.

INSTALLATION

Troubleshooting

Problem	Cause	Action
Unit will not turn on (no power LED indicator)	BAT+ wire not connected or incorrect voltage REM wire not connected or incorrect voltage	Check connections for proper voltage (11~16VDC)
	GND wire not connected	Check connection to ground
	Fuse(s) blown	Replace fuse(s)
Unit has power - LED is green (but no sound)	Volume turned all the way down	Increase volume level at head unit
	Speaker defective or damaged	Check/replace speaker
	Input signal not connected	Check high or low level inputs for proper connection
Unit blows fuse(s)	Incorrect fuse rating	Use fuse(s) with correct rating
	BAT+ wire touching chassis ground	Check for pinched wire
	Speaker defective or damaged	Check/replace speaker
Engine noise	Bad ground connection	Make sure amplifier is grounded to clean bare metal
	Signal ground loop or RFI (radio frequency interference)	Re-route RCA cables from existing high current wiring
Distorted audio output	Incorrect input signal type or input level too high	Check connections and reduce/adjust input level
Low audio output	Incorrect input signal type or input level too low	Check connections and increase or adjust input level
Weak bass	Low frequency output is out of phase	Adjust phase control as needed

WARRANTY

Limited One-Year Warranty

This warranty gives you specific legal rights. You may also have other rights which vary from state to state.

Dual Electronics Corp. warrants this product to the original purchaser to be free from defects in material and workmanship for a period of one year from the date of the original purchase.

Dual Electronics Corp. agrees, at our option, during the warranty period, to repair any defect in material or workmanship or to furnish an equal new, renewed or comparable product (whichever is deemed necessary) in exchange without charges, subject to verification of the defect or malfunction and proof of the date of purchase. Subsequent replacement products are warranted for the balance of the original warranty period.

Who is covered? This warranty is extended to the original retail purchaser for products purchased from an authorized Dual dealer and used in the U.S.A.

What is covered? This warranty covers all defects in material and workmanship in this product. The following are not covered: software, installation/removal costs, damage resulting from accident, misuse, abuse, neglect, product modification, improper installation, incorrect line voltage, unauthorized repair or failure to follow instructions supplied with the product, or damage occurring during return shipment of the product. Specific license conditions and copyright notices for the software can be found via www.dualav.com.

What to do?

1. Before you call for service, check the troubleshooting guide in your owner's manual. A slight adjustment of any custom controls may save you a service call.
2. If you require service during the warranty period, you must carefully pack the product (preferably in the original package) and ship it by prepaid transportation with a copy of the original receipt from the retailer to an authorized service center.
3. Please describe your problem in writing and include your name, a return UPS shipping address (P.O. Box not acceptable), and a daytime phone number with your shipment.
4. For more information and for the location of the nearest authorized service center please contact us by one of the following methods:
 - Call us toll-free at 1-866-382-5476
 - E-mail us at cs@dualav.com

Exclusion of Certain Damages: This warranty is exclusive and in lieu of any and all other warranties, expressed or implied, including without limitation the implied warranties of merchantability and fitness for a particular purpose and any obligation, liability, right, claim or remedy in contract or tort, whether or not arising from the company's negligence, actual or imputed. No person or representative is authorized to assume for the company any other liability in connection with the sale of this product. In no event shall the company be liable for indirect, incidental or consequential damages.

INSTALLATION

Notes

For Your Records

Please keep your original sales receipt and be prepared to provide this receipt in the event you require service, as your original receipt is considered the best proof of purchase and indicates the date you purchased your Dual product.

Dealer Name _____

Dealer Phone _____

Purchase Date _____

Register Your Product

Register your product online at www.dualav.com

INSTALLATION

Specifications

Maximum Output Power	300 watts
Continuous Output Power	100 watts
Frequency Response	20-200Hz
S/N Ratio @ 1 watt	85dB
Input Impedance	Low level (RCA): 10k ohms
Input Sensitivity (RCA)	50mV – 3V
Crossover Frequency	40–160Hz
Crossover Slope	6dB/octave
Phase	0–180 degrees
Fuse	15 amp ATO
Dimensions	12.6" x 16.5" x 9.8" (HxWxD)

Design and specifications subject to change without notice.



Dual Electronics Corp.
Toll Free: 1-866-382-5476
Monday-Friday, 9AM-5PM EST

www.dualav.com
©2013 Dual Electronics Corp. All rights reserved.
NSA0513-V01
Printed in China